



**TJ-70 HEATER ASSEMBLY  
PACE P/N 6010-0084-P1  
INSTALLATION INSTRUCTIONS  
MANUAL NUMBER 5050-0351 REV. C**

Ensure that the installed Heater Assembly or your handpiece is defective by referring to the "TJ-70 Heater Assembly Checkout Procedure" in either of the handpiece manuals (P/N 5050-0338 or 5050-0350). To replace the TJ-70 Heater Assembly, follow the procedure listed below using the illustration as guide to ensure optimum results:

1. Disconnect the Mini ThermoJet handpiece (TJ-70 or TJ-65) from the power receptacle of the system power source.
2. Remove the end cap assembly and attached metal chamber from the handpiece.
3. Remove the 3 Heater Assembly Screws. Allow the assembly to hang loose. DO NOT pull the Heater Assembly from the handpiece at this time.
4. Remove the 2 Heat Dissipator Screws which attach the Heat Dissipator to the Handpiece (Bottom). DO NOT remove the third screw attaching the Heat Dissipator to the Handpiece (Top).
5. Remove the 2 C Clips located at the rear of the handpiece.
6. Remove the 2 Handpiece Mounting Screws.
7. Remove the Handpiece (Bottom).
8. Remove the 2 Cord & Switch Assembly Screws. Set the PCB Cover aside.
9. Using needle nose pliers, disconnect the 5 Heater Assembly leads plugged into the Cord & Switch Assembly. Remove the defective Heater Assembly from the handpiece and discard.
10. Using needle nose pliers, carefully plug the 5 color coded leads of the replacement Heater Assembly into the receptacles of the Cord & Switch Assembly pcb. Plug the Tan Leads into the receptacles along either edge of the pcb (#1 & #5; see PCB Cover markings on illustration). Plug the Green Lead into the center receptacle (#3). Plug the 2 Orange Leads into the remaining receptacles (#2 & #4).
11. place the PCB Cover back over the Cord & Switch Assembly. Reattach to the handpiece using the 2 Cord & Switch Assembly Screws removed in step 8.
12. Reassemble the handpiece in the following order.
  - a) Replace the Handpiece (Bottom) removed in step 7.
  - b) Replace the 2 Handpiece Mounting Screws removed in step 6.
  - c) Replace the 2 C Clips removed in step 5.
  - d) Replace the 2 Heat Dissipator Screws removed in step 4.
  - e) Replace the 3 Heater Assembly Screws removed in step 3.
  - f) Replace the end cap assembly and metal chamber removed in step 2.
13. Remove the Blue, plastic cover from the end of the Heater Assembly. Connect the handpiece to the system power source and follow the burn-in procedure listed on the Red tag shipped with the replacement Heater.

**CAUTION**

Insure that the pcb receptacles face up against the PCB Cover and the cable assembly wires are not pinched during the Cord & Switch Assembly Screw installation.

©2005 PACE Incorporated, Annapolis Junction, MD All Rights Reserved. Printed in the USA  
[www.paceworldwide.com](http://www.paceworldwide.com)

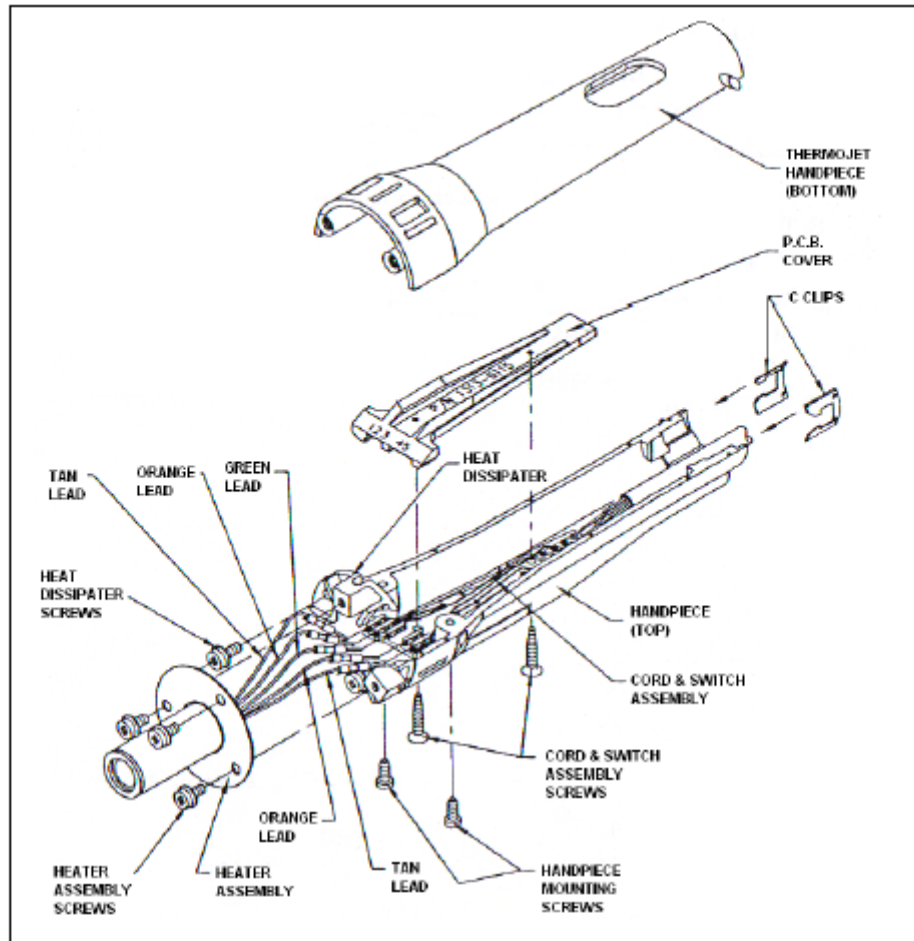

PACE Incorporated retains the right to make changes to specifications contained herein at any time, without notice. Contact your local authorized PACE Distributor or PACE Incorporated to obtain the latest specifications.

The following are trademarks and/or service marks of PACE, Incorporated, MD, USA:

INSTACAL™, FUMEFLO™, HEATWISE™, PACEWORLDWIDE™, PERMAGROUND™, POWERPORT™, POWERMODULE™, TEMPWISE™, TIP-BRITE™, AUTO-OFF™, and TEKLINK™.

The following are registered trademarks and/or service marks of PACE Incorporated, Annapolis Junction Maryland U.S.A.

ARM-EVAC®, FLO-D-SODR®, MINIWAVE®, PACE®, SENSATEMP®, SNAP-VAC®, SODRTEK®, SODR-X-TRACTOR®, ST 325®, THERMOJET®, THERMOTWEEZ®, VISIFILTER®, THERMO-DRIVE®, and TOOLNET®.

PACE products meet or exceed all applicable military and civilian EOS/ESD, temperature stability and other specifications including MIL STD 2000, ANSI/JSTD 001, IPC7711, and IPC A-610.

Additional copies of this manual or other PACE literature may be obtained from:



**PACE Incorporated**  
9030 Junction Drive  
Annapolis Junction,  
MD 20701  
Tel: (301) 490-9860  
Fax: (301) 498-3252

**PACE Europe Limited**  
13 Tanners Drive  
Blakelands  
Milton Keynes  
Tel: (44) 1908-277686  
Fax: (44) 1908-277777

©2005 PACE Incorporated, Annapolis Junction, MD All Rights Reserved. Printed in the USA  
[www.paceworldwide.com](http://www.paceworldwide.com)